

SMA-RP Connectors Series



Content.....	Page
Description	2
Interface Dimensions	2
Interface Dimensions in mm/inches	2
Characteristics	3
Cable Connectors	4
PCB Connectors	7
Adapter Connectors	7
Assembly Instruction	9

Description

The RP-SMA connector has the same performance, usage and external housing as SMA connector. Its compact design, high durability and outstanding electrical performance have made it one of the most widely used connectors in RF and Microwave applications. The main differences between them lie in which the male and female interface is switched. The internal prong or pin of the RP-SMA plug connector is replaced by a receptacle. Similarly, The RP-SMA female connector keeps the female receptacle, but is housed in a plug casing.

Interface Dimensions

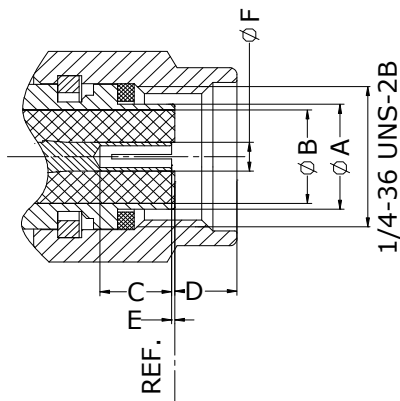

Plug (male)

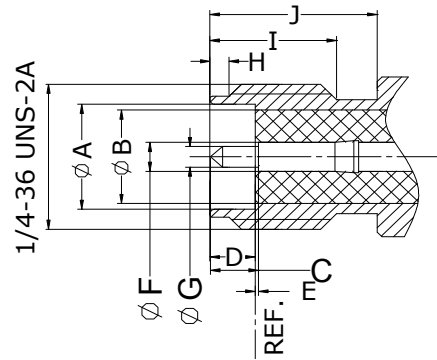

Jack (female)

Interface Dimensions (mm/inches)

	Plug		Jack	
	min.	max.	min.	max.
A	-	4.95/.181	4.59/.181	-
B	-	4.18/.165	-	4.18/.165
C	2.67/.105	-	-	2.54/.100
D	1.88/.074	1.98/.078	0.38/.015	1.14/.045
E	0.00/.000	0.25/.010	0.00/.000	0.25/.010
F	1.24/.049	1.29/.051	1.24/.049	1.29/.051
G	-	-	0.90/.036	0.94/.037
H	-	-	0.38/.015	1.14/.045
I	-	-	4.32/.170	-
J	-	-	5.54/.218	-

Characteristics

ELECTRICAL	REQUIREMENTS
Impedance	50
Frequency range	DC to 18 GHz
Dielectric Withstanding Voltage	2500 V rms 50 Hz, sea level
Working Voltage	≤1,000 V rms 50 Hz, sea level
VSWR	Straight connector, .141": ≤1.23 (DC~18GHZ)
	Straight connector, RG316: ≤1.19 (DC~6GHZ)
	Right angle connector, .141": ≤1.39 (DC~18GHZ)
	Right angle connector, RG316: ≤1.28 (DC~6GHZ)
Insulation Resistance	5×10 ³ MΩ min.(initial)
Contact Resistance	
- Center contact	3.0 m max..
- Outer contact	2.5 m max.
RF-leakage	
DC to 3 GHz	-90 dB min.
3 GHz to 6 GHz	-75 dB min.

MECHANICAL	REQUIREMENTS
Recommended Coupling Nut Torque	Standard: 0.8 Nm~1.1 Nm / 7.1~9.7 in. lbs Brass: 0.45 Nm /4.0 in. lbs
Coupling Nut Retention Force	≥270 N /60.7 lbs
Contact Captivation	Axial: ≥27 N/6.1 lbs
Cable Retention Force	
- cable 2.6/50	110 N/25 lbs
- cable 5/50	150 N/33.75 lbs (single braid) 200 N/48 lbs (double braid)
-cable .085/50	135 N/30 lbs
-cable .141	270 N/60.75 lbs
Durability (Mating Cycles)	500 min.

ENVIRONMENTAL	REQUIREMENTS
Temperature Range	-65°C to +165°C
Climactic Category	IEC→55/155/21
Corrosion	Salt spray test acc. to MIL-STD-202, Method 101, Condition B
Moisture Resistance	MIL-STD-202 F, Method 106
Vibration	MIL-STD-202, Method 204, Condition D
Shock	MIL-STD-202, Method 213, Condition I

Note: The above characteristics are typical but may not apply to all connectors.

Cable Connectors

Straight Cable Plugs (male)

>for flexible cables

Part No.	Cable Group (Example)	Finish	Remarks	Assembly Instruction
ANO 2113-2048	2/50/S (RG78)	Nickel	Solder	AI 01

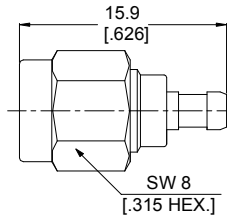

>for flexible cables

Part No.	Cable Group (Example)	Finish	Remarks	Assembly Instruction
ANO 2113-2009	2.6/50/S/D (RG316/LMR100)	Gold	Crimp	AI 02

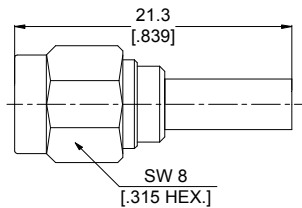

>for flexible cables

Part No.	Cable Group (Example)	Finish	Remarks	Assembly Instruction
ANO 2113-2010	5/50/S/D (RG58/LMR195)	Nickel	Crimp	AI 02

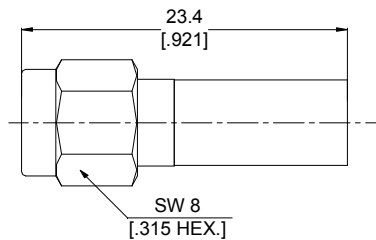

>for flexible cables

Part No.	Cable Group (Example)	Finish	Remarks	Assembly Instruction
ANO 2113-2047	6/50 /D (LMR240)	Albaloy	Crimp	AI 02

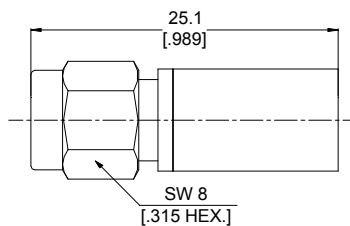

Right Angle Cable Plugs (male)

>for flexible cables

Part No.	Cable Group (Example)	Finish	Remarks	Assembly Instruction
ANO 2123-2053	2.6/50/S/D (RG316/LMR100)	Gold	Crimp	AI 03

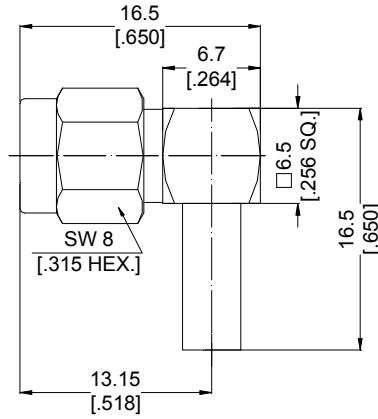

>for flexible cables

Part No.	Cable Group (Example)	Finish	Remarks	Assembly Instruction
ANO 2123-2025	5/50/S/D (R68/LMR195)	Nickel	Crimp	AI 04
ANO 2123-2040	5/50/S/D (R68/LMR195)	Gold	Crimp	AI 04

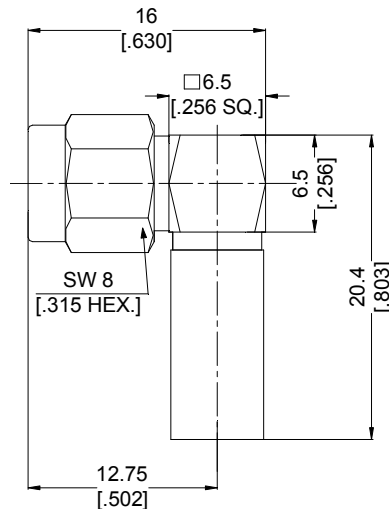

Straight Cable Jacks (female)

>for flexible cables

Part No.	Cable Group (Example)	Finish	Remarks	Assembly Instruction/Mounting Hole
ANO 2114-1011	2/50/S (R678)	Gold	Solder	AI 01/MH 3

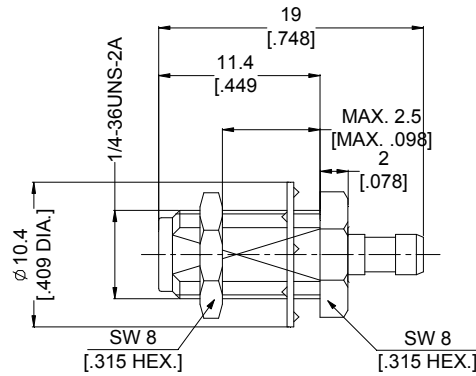

>for flexible cables

Part No.	Cable Group (Example)	Finish	Remarks	Assembly Instruction/Mounting Hole
ANO 2114-1013	2.6/50/S/D (RG316/LMR100)	Gold	Crimp	AI 02/MH 3

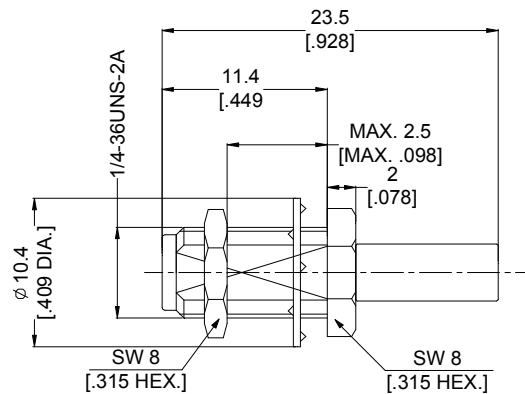

Straight Bulkhead Cable Jacks (female)

>for flexible cables

Part No.	Cable Group (Example)	Finish	Remarks	Assembly Instruction/Mounting Hole
ANO 2114-1037	2/50/S (R678)	Gold	Solder	AI 01/MH 3

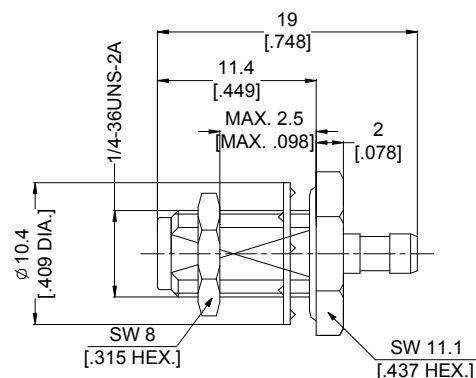

PCB Connectors

Straight PCB jacks (female)

Part No.	Finish	Mounting Hole
ANO 2114-4027	Gold	MH 22

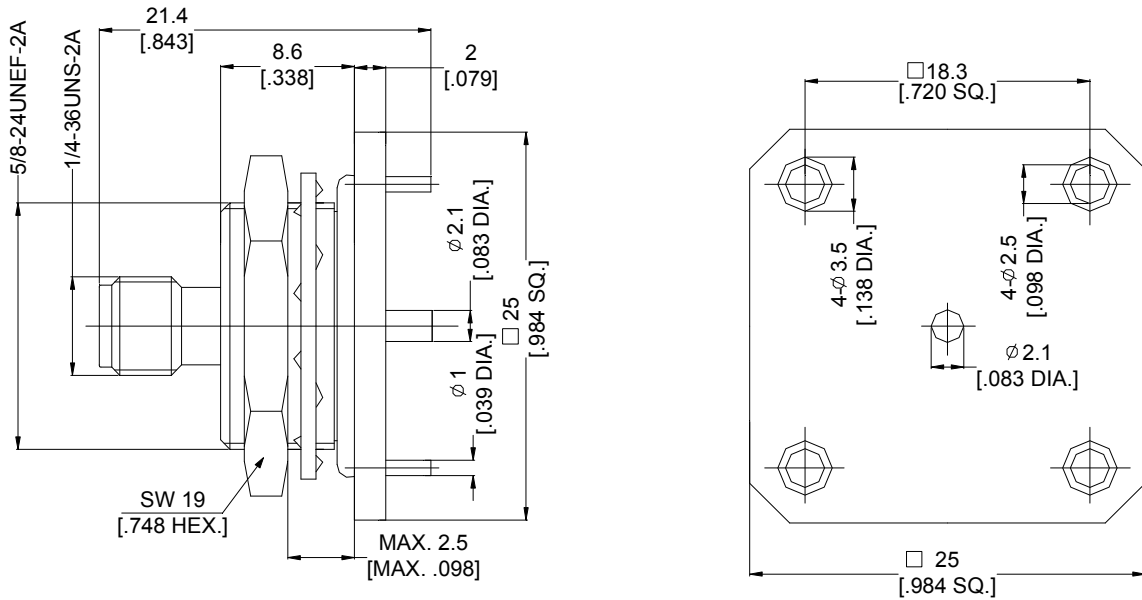

Adapter Connectors

Adapter jack/jack (female/female)

Part No.	Finish	Type / Type	Mounting Hole
ANO 212-214-1005	Gold	SMA(jack) /SMA-RP(jack)	MH 3

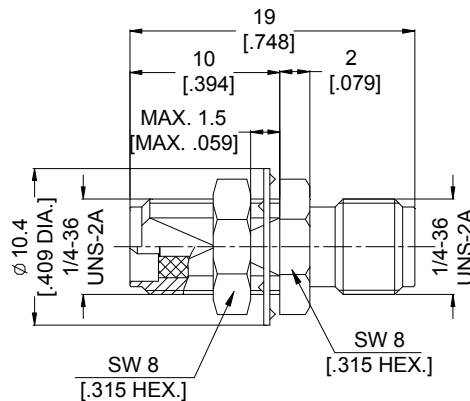

Adapter plug/jack (male/female)

Part No.	Finish	Type / Type
ANO 511-214-1010	Nickel	SMA-RP(jack) / N(plug)

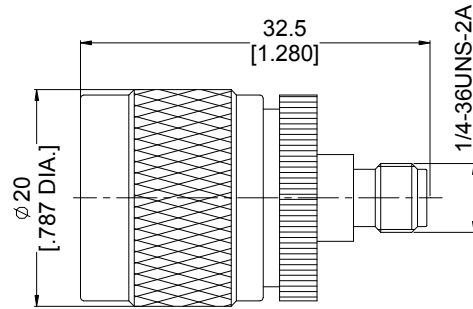

Adapter plug/jack (male/female)

Part No.	Finish	Type / Type
ANO 214-333-1021	Nickel	SMA-RP(jack) / TNC-RP(plug)

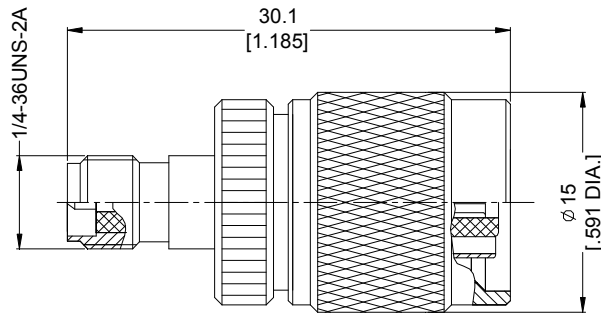

Assembly Instruction

AI 01

Part No.	Cable Group (Example)	Stripping Length		
		a	b	c
ANO 2113-2048	2/50/S (RG78)	2.0	2.0	5.0
ANO 2114-1011		3.0	1.5	8.1
ANO 2114-1037				

①

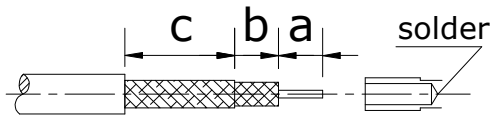

②

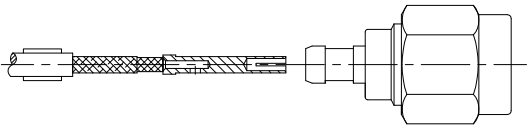

③

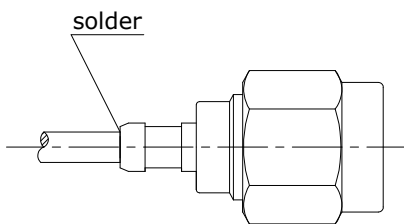

④

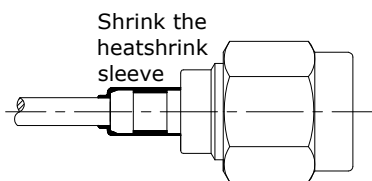

- 1.1 Slide onto the cable the heatshrink sleeve.
- 1.2 Strip the cable.
- 1.3 Slide on center contact until it bottoms against cable dielectrique.
- 1.4 Solder center contact.

- 2.1 Slide the cable into the body until it bottoms against insulator.

- 3.1 Solder the body onto the cable.
- 3.2 Clean soldering area.

- 4.1 Slide sleeve over soldering area and heatshrink in place.

AI 02

Part No.	Cable Group (Example)	Stripping Length		
		a	b	c
ANO 2113-2009	2.6/50/S/D (RG316/LMR100)	2.0	2.0	6.0
ANO 2114-1013		3.0	2.8	6.0
ANO 2113-2047	6/50 /D (LMR240)	2.5	7.5	8.0
ANO 2113-2010	5/50/S/D (RG316/LMR195)	2.5	7.5	8.0

①

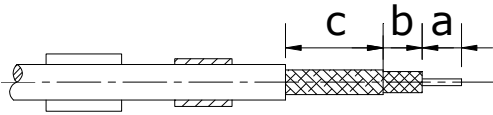

②

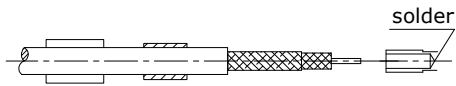

③

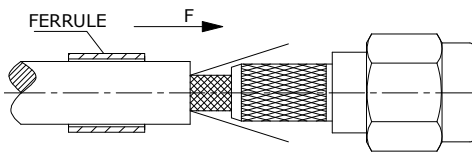

④

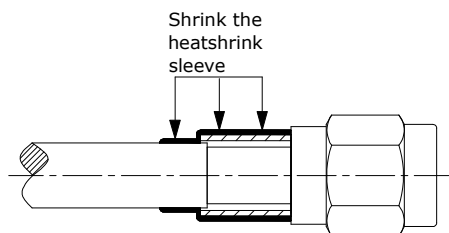

- 1.1 Slide onto the cable the heatshrink sleeve and the ferrule.
- 1.2 Strip the cable.

- 2.1 Slide on center contact until it bottoms against cable dielectric.
- 2.2 Solder center contact.
- 2.3 Clean soldering area.

- 3.1 Fan the braid.
- 3.2 Slide the cable into the body until it bottoms against insulator.
- 3.3 Slide the ferrule over the braid.
(In direction F)

- 4.1 Cut the excess of braid.
- 4.2 Crimp the ferrule.
- 4.3 Slide sleeve over ferrule and heatshrink in place.

AI 03

Part No.	Cable Group (Example)	Stripping Length		
		a	b	c
ANO 2123-2053	2.6/50/S/D (RG316/LMR100)	1.6	2.9	6.0

①

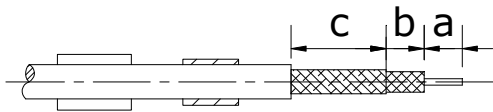

- 1.1 Slide onto the cable the heatshrink sleeve and the ferrule.
- 1.2 Strip the cable.

②

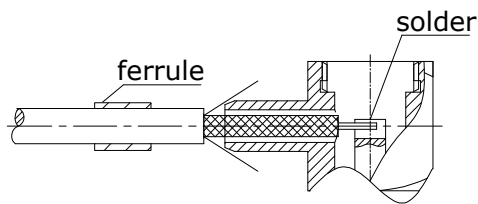

- 2.1 Fan the braid.
- 2.2 Push connector body under the braid.
- 2.3 Solder inner conductor.
- 2.4 Slide the ferrule over the braid.

③

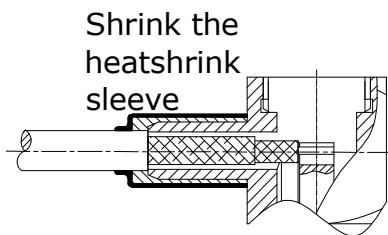

- 3.1 Cut the excess of braid.
- 3.2 Crimp the ferrule.
- 3.3 Slide sleeve over ferrule and heatshrink in place.

④

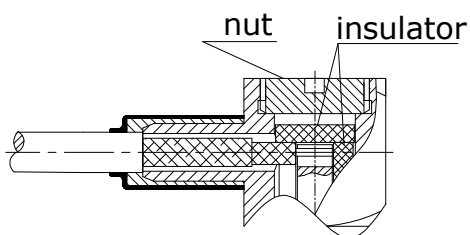

- 4.1 Mount the insulator.
- 4.2 Screw the nut into the body

AI 04

Part No.	Cable Group (Example)	Stripping Length		
		a	b	c
ANO 2123-2025	5/50/S/D (R68/LMR195)	1.7	3.8	8.0
ANO 2123-2040				

①

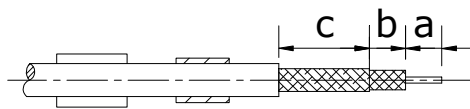

②

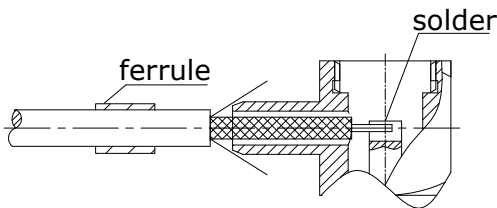

③

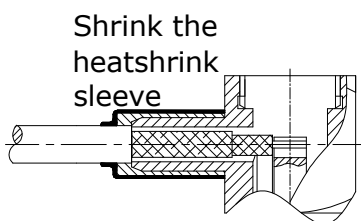

④

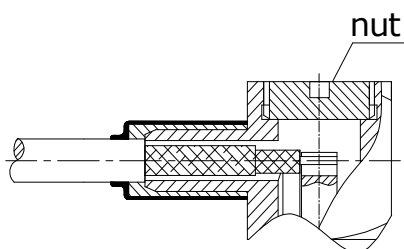

- 1.1 Slide onto the cable the heatshrink sleeve and the ferrule.
- 1.2 Strip the cable.

- 2.1 Fan the braid.
- 2.2 Push connector body under the braid.
- 2.3 Solder inner conductor.
- 2.4 Slide the ferrule over the braid.

- 3.1 Cut the excess of braid.
- 3.2 Crimp the ferrule.
- 3.3 Slide sleeve over ferrule and heatshrink in place.

- 4.1 Screw the nut into the body